

iTalent Series Dual Row Cabinet Data Center

Product Introduction ▼

iTalent series dual row cabinet data center adopts modular design, integrating power supply and distribution system, air conditioning system, cabinet system, closed aisle system, monitoring system and cabling system into one, and configuring various environmental data sampling sensors for unified monitoring and management by eSite cloud map monitoring system, realizing automatic control and intelligent operation and maintenance, enhancing data center reliability, availability and maintainability.



Product Features ▼



Safe and reliable

- All components are manufactured according to international and domestic standards to ensure product quality;
- Data center productization, productization reliability up to 99.999%. Adopt integrated design to enhance the overall reliability of the system;
- Redundant design of key components to improve system reliability;
- The data center power distribution and cooling system is designed according to the international class A server room (international standard Tier IV level);
- Integrated intelligent monitoring system, early warning of key data to ensure the safety of server room operations reliable.



Easy installation

- Standardized components, modular architecture, and rapid on-demand deployment to match your business;
- No need for professional machine room, can be installed directly on the concrete floor of the building, reducing the supporting engineering;
- The products are standardized, modular, plug-and-play, and easy to be installed, greatly reducing the installation cycle.



High efficiency and energy saving

- The average annual PUE can be reduced to 1.30;
- The use of in-row air conditioner cooling, closed cooling space to achieve precise cooling near the server side, greatly improving the efficiency of cooling, comparing with the traditional server room can save energy by more than 35%;
- N+X high efficiency online modular UPS with intelligent sleep function to save more energy;
- High density deployment, single cabinet up to 10kW;
- Integrated power supply and distribution, space saving, 1-2 more equipment cabinets can be deployed;
- Remote O&M is unattended, saving TCO.



Intelligent management

- Intelligent monitoring of the working status of power and environmental systems;
- Intelligent intel, visual display of key information, easy operation and maintenance;
- Real-time alerts can be made in time by SMS, telephone, email, sound and light, etc;
- Provide a variety of human-machine interaction methods such as operation and maintenance large screen, remote APP, local LCD and remote WEB;
- Provide a variety of northbound interfaces such as ModbusTCP, MQTT, etc. for easy system integration.

Parameters ▼

iTalent series dual row cabinet data center			
		Parameters	
System	Size(W*D*H)	3600*L*2600mm (L≤15000mm)	
	IT rated power/cabinet	3~10kW	
	Door Specifications	Automatic sliding doors/manual sliding doors/pull-out doors	
	Intelligent Lighting	LED white light, intelligent color ambient light, linkage with monitoring system.	
	Access Control System	Support face/fingerprint/password/IC and other methods can be selected	
	Ambient temperature	0-45°C	
	Ambient Humidity	10-95%, Relative Humidity	
	Protection class	IP20	
	Altitude	1000 m, more than 1000 m need to be derated.	
	Installation method	Direct concrete floor installation / Raised floor installation	
Cabinet	Size(W*D*H)	600/800*1200*2000mm	
	Available Space	42U	
	Inlet method	Support up/down wire feed	
Power Distribution System	Power Distribution Cabinet	Input method	Single circuit MCCB/Dual circuit ATS
		Grid system	380/400/415Vac, 50/60Hz
		Specification	63~400A
		SPD	B/C class optional
		Type	Integrated UPS distribution cabinet/precision distribution cabinet/intelligent busbar
	UPS	Capacity	Built-in maximum 200kVA, external 200kVA or more
		Input Freq.	40-70Hz
		Output PF	1
		Battery	Built-in cabinet type battery cabinet or external battery cabinet
	PDU	Ordinary Type	[National standard 12-bit 10A + 3-bit 16A]*2
Smart Type		24-port intelligent PDU (optional)	
Cooling System	Air Conditioner Capacity	12.5~60kW	
	Cooling method	Air-cooled	
	Refrigerant	R410A	
Monitoring System	HMI	21.5 inch touch screen	
	System Functions	Remote WEB/Centralized monitoring of power, environment, video, access control system/Northbound interface	
	Monitoring accessories	Smoke sensor/T&H sensor/water flood sensor/infrared sensor/webcam/access control/fire linkage	
	Alarm method	E-mail / SMS, Audible and visual alarm, Telephone Voice, APP(optional)	

The above parameters are for reference, the actual configuration parameters are subject to customer requirements.

Applicable Scene ▼

Large-scale data center, campus data center and other core business server room, suitable for Government, medical, education, finance, telecom and other leasing and self-use businesses.



Applicable power ▼

The maximum supported power of a single cabinet is 10kW per cabinet. And it supports up to 50 cabinet which includes air conditioner and power distribution cabinet.

Air flow organization reference chart ▼

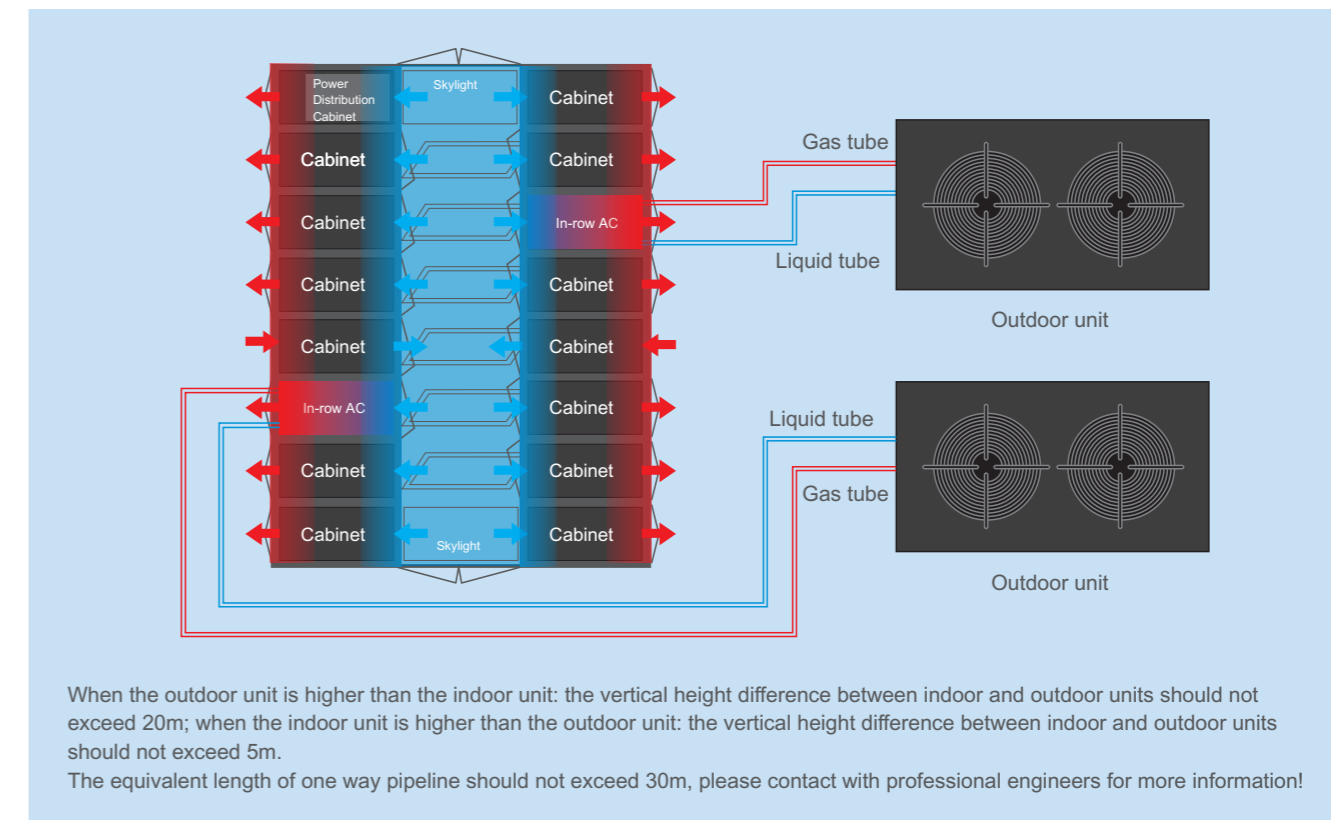

Diversified configurations ▼



Integrated Data Center Application Scenario Diagram ▼

